

THE INFORMATION CONTAINED IN THIS DRAWING IS THE SOLE PROPERTY OF AMERICAN STAINLESS PUMPS ANY REPRODUCTION IN PART OR WHOLE WITHOUT THE WRITTEN PERMISSION OF AMERICAN STAINLESS PUMPS IS PROHIBITED.

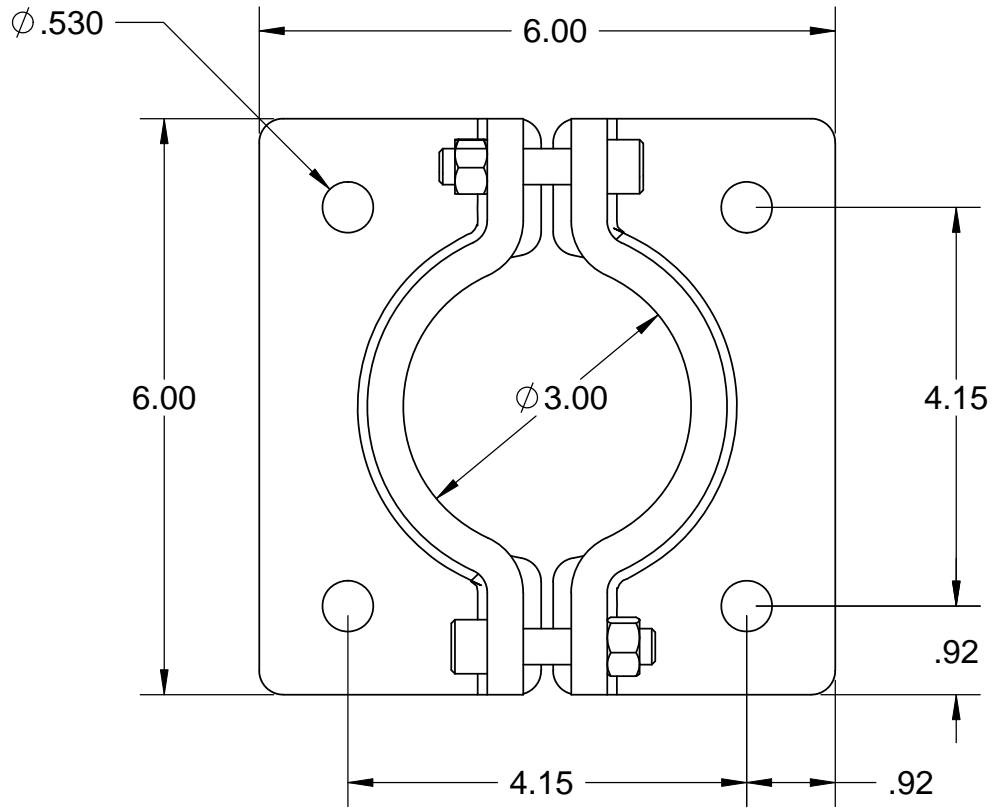
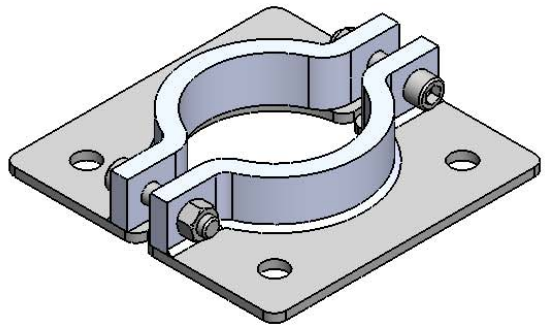
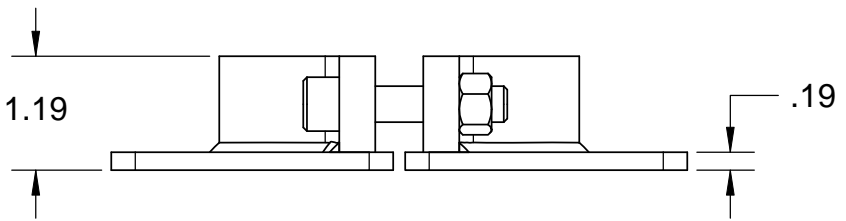

MATERIAL: Mild steel welded and painted

MANUFACTURING PROCESS:

CAD GENERATED DRAWING NOT FOR CONSTRUCTION UNLESS INDICATED. DO NOT SCALE DRAWING.



PART NO. **811010** SHEET NAME: **Clamp Assy Drawing**

DRAWN BY: MWC FILE NAME: **Column Mount Clamp Assy** REV. **0** DATE **5/19/10**

CHECKED BY: MFB RELEASED BY: BOTH SHEET: A SCALE: 1:3 PATH: SHEET 1 OF 1

RELEASED FOR CONSTRUCTION? **YES**

TOLERANCES UNLESS OTHERWISE INDICATED

FRACTIONS	DECIMAL	ANGULAR
1/X ± 1/32	X ± 0.015	X ± 5°
1/XX ± 1/64	.XX ± 0.01	.X ± 1°
	.XXX ± 0.005	XX ± .02°
	.XXXX ± 0.001	

WHEN NOT NOTED OTHERWISE

ALL DIMENSIONS IN INCHES. CHAMFER MACHINED EDGES 0.03. REMOVE ALL BURRS. FILLET CORNERS 0.06. RADIAL & DIAMETRICAL DIMENSIONS ARE TO BE HELD TO A ±.002 MACHINED FACES SURFACE FINISH 63. SYMMETRICAL TOLERANCE, AND ARE CONCENTRIC WITH PART CENTERLINES. QUESTIONS? CALL 310-630-8089. EMAIL: MCOOL@ASPUMPS.COM

REV.	REVISION DESCRIPTION	DATE
0	ORIGINAL DOCUMENT	