



# **AMERICAN STAINLESS PUMPS**

Stainless Steel Pumps for the Commercial Marketplace



## **The Toughest Stamped Stainless Pumps on the Market!**

- American made products at a competitive price
- Nozzles & fittings can be customized for Original Equipment Manufacturers
- Quick leadtimes for stock or custom products
- Pumps built to order per customer specifications

## **Multiple Motor Options Available!**

- ODP or TEFC
- Washdown Duty, Explosion Proof, All Stainless Steel
- Single or Three Phase
- 50/60 Hz
- 575V

## **Features**

- Open and Enclosed Impellers
- Close Coupled Pumps
- Back pullout pump design for easy access...no piping removal
- All Stainless Steel Wetted Parts

## **Applications**

Dishmachines  
Chillers  
Breweries  
Parts Washers  
Water Circulation  
Filtration Systems  
Commercial Laundry



## SSP/C CENTRIFUGAL PUMPS

- Flow Rates up to 250gpm
- System pressures up to 125 psig
- Temperatures up to 250°F
- Impellers up to 5.75" diameter produce 55psig
- Service in both 50 and 60Hz
- 1.0" x 1.25" and 1.5"x2.0" NPT connections available



- Close Coupled End Suction Centrifugal Pumps for the Commercial Marketplace
- Stamped Stainless components provide high efficiencies
- Thick nozzles prevent damage during piping
- Multiple mechanical seal configurations
- Vertical mounting acceptable

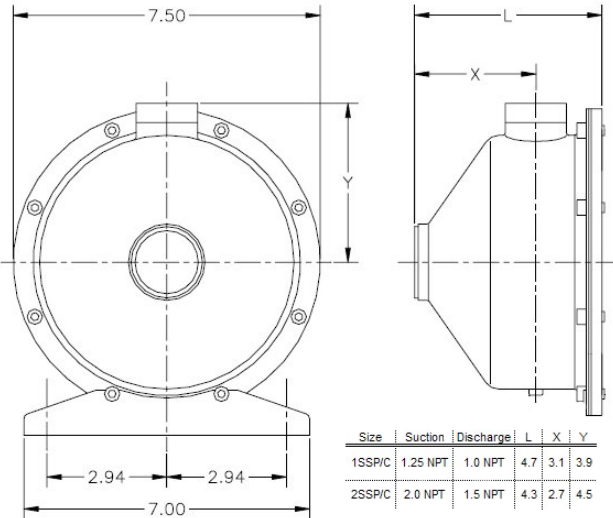

## 7SP CENTRIFUGAL PUMPS

- Single stage high pressure pump produces up to 88 psig
- Flow Rates up to 70gpm
- System pressures up to 120 psig
- Temperatures up to 250°F
- Impellers up to 7.24" in diameter
- Service in both 50 and 60Hz
- 56J Frame: 2 through 5HP motors available
- 1.0" x 1.25" NPT Connections
- Multiple mechanical seal configurations



## TSP TWO STAGE PUMPS

- Two stage high pressure pump produces up to 115 psig
- Flow Rates up to 63gpm
- System pressures up to 120 psig
- Temperatures up to 250°F
- Impellers up to 6.7" in diameter
- Service in both 50 and 60Hz
- 56J Frame: 2 through 5HP motors available
- 1.0" x 1.25" NPT Connections
- Multiple mechanical seal configurations



## FSP CENTRIFUGAL PUMPS

- Flow Rates up to 70gpm
- System pressures up to 50 psig
- Temperatures up to 250°F
- Impellers produce up to 29.5psig
- Our smallest and least expensive pump
- Close Coupled End Suction Centrifugal Pumps for the Commercial Marketplace
- Stamped Stainless components provide high efficiencies
- Thick nozzles prevent distortion when piping

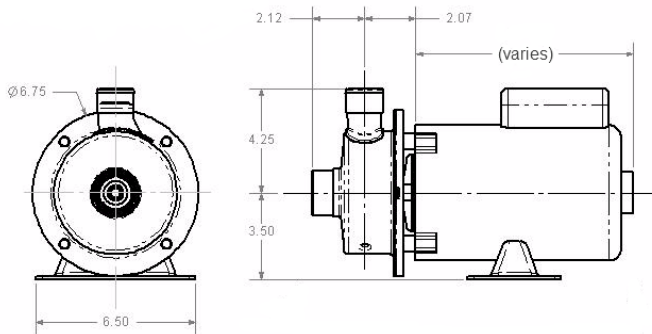

**Customize your nozzles for OEM applications!!!**

## SPV VERTICAL PUMPS

- 12" and 24" sump depths standard
- Custom sump depths available
- Flow Rates up to 240gpm
- System pressures up to 120 psig
- Temperatures up to 250°F
- Impellers up to 5.75" in diameter produce 55 psig
- Service in both 50 and 60Hz
- 56J Frame: 2 through 5HP motors available
- Extended shaft or cantilever pumps available
- No more hard to find metric fasteners!
- Bearings available in variety of materials

**No mechanical seal or packing required!**

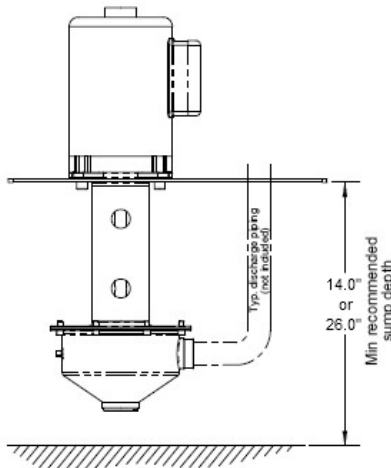
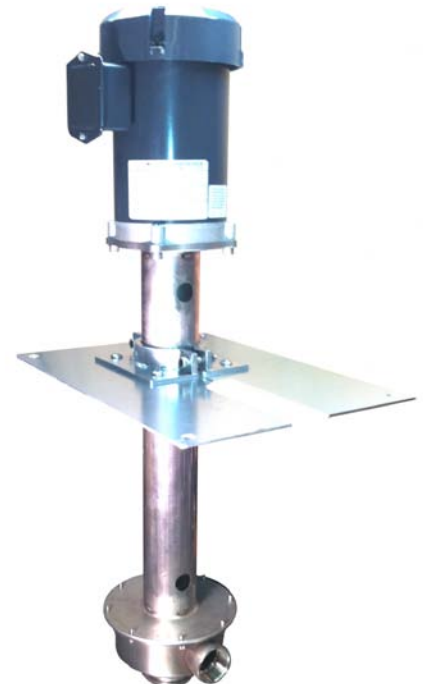

**Same performance curves as the SSP horizontal pump**

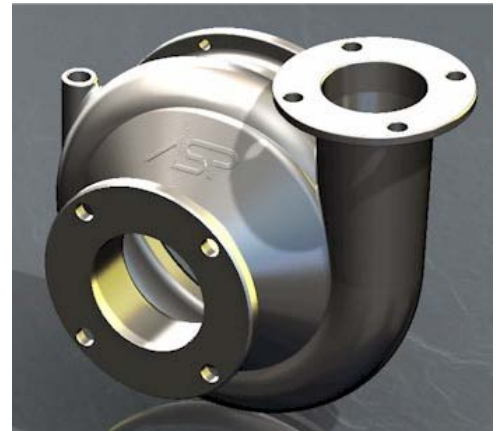
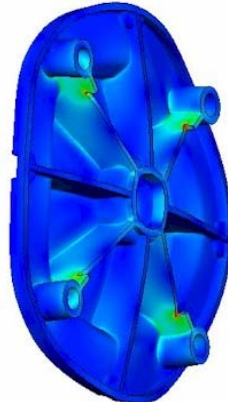
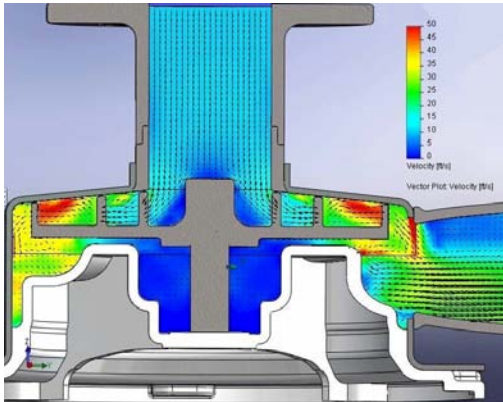
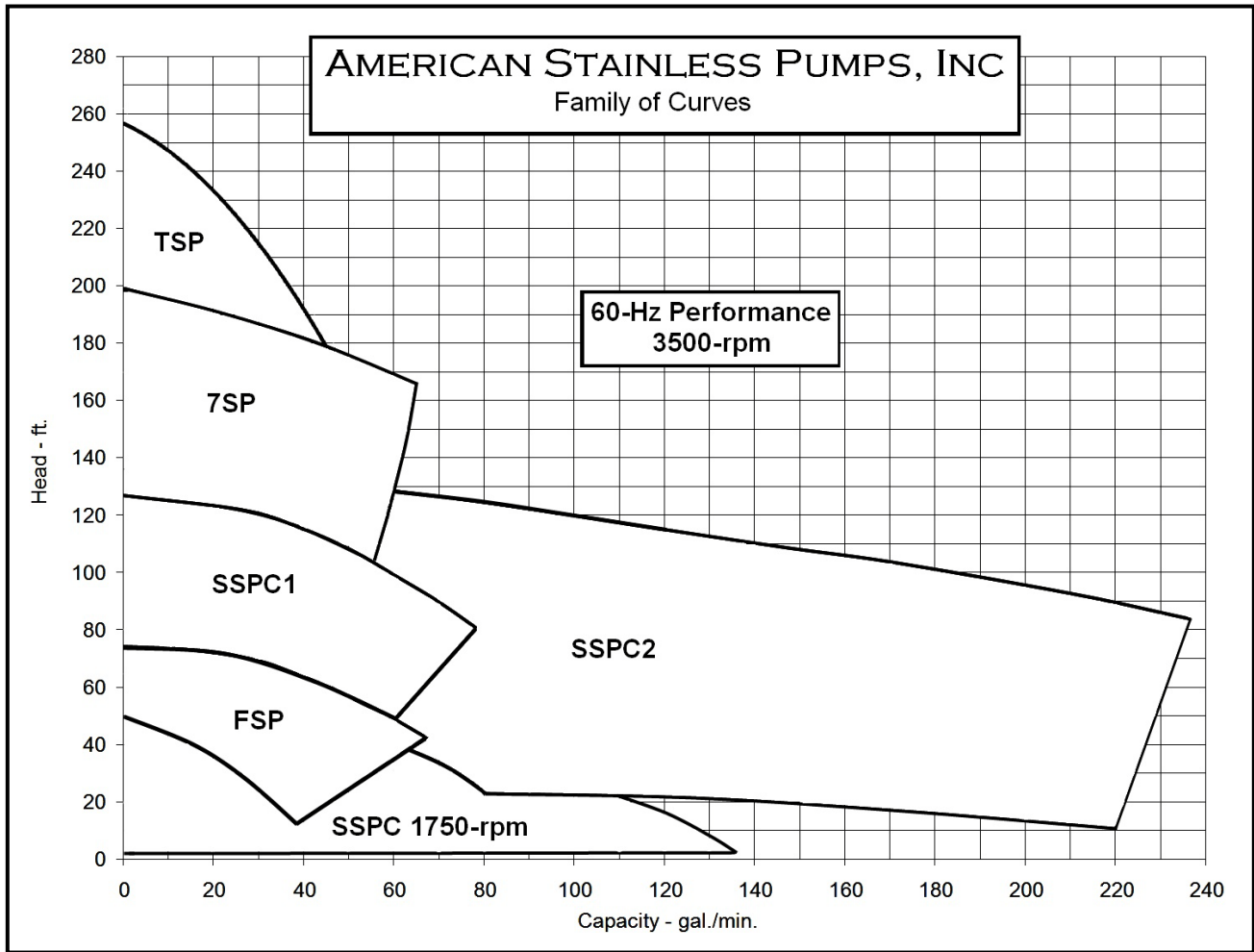

ASP engineering takes advantage of the latest CFD and FEA analysis software to ensure our products' design quality and efficiency

Custom pumps and nozzles for OEM applications



# AMERICAN STAINLESS PUMPS

Stainless Steel Pumps for the Commercial Marketplace

14032 Avalon Blvd #C. Los Angeles, CA 90061  
 Phone (310) 630-8089 ~ Fax (310) 630-8095  
 Email: support@aspumps.com