

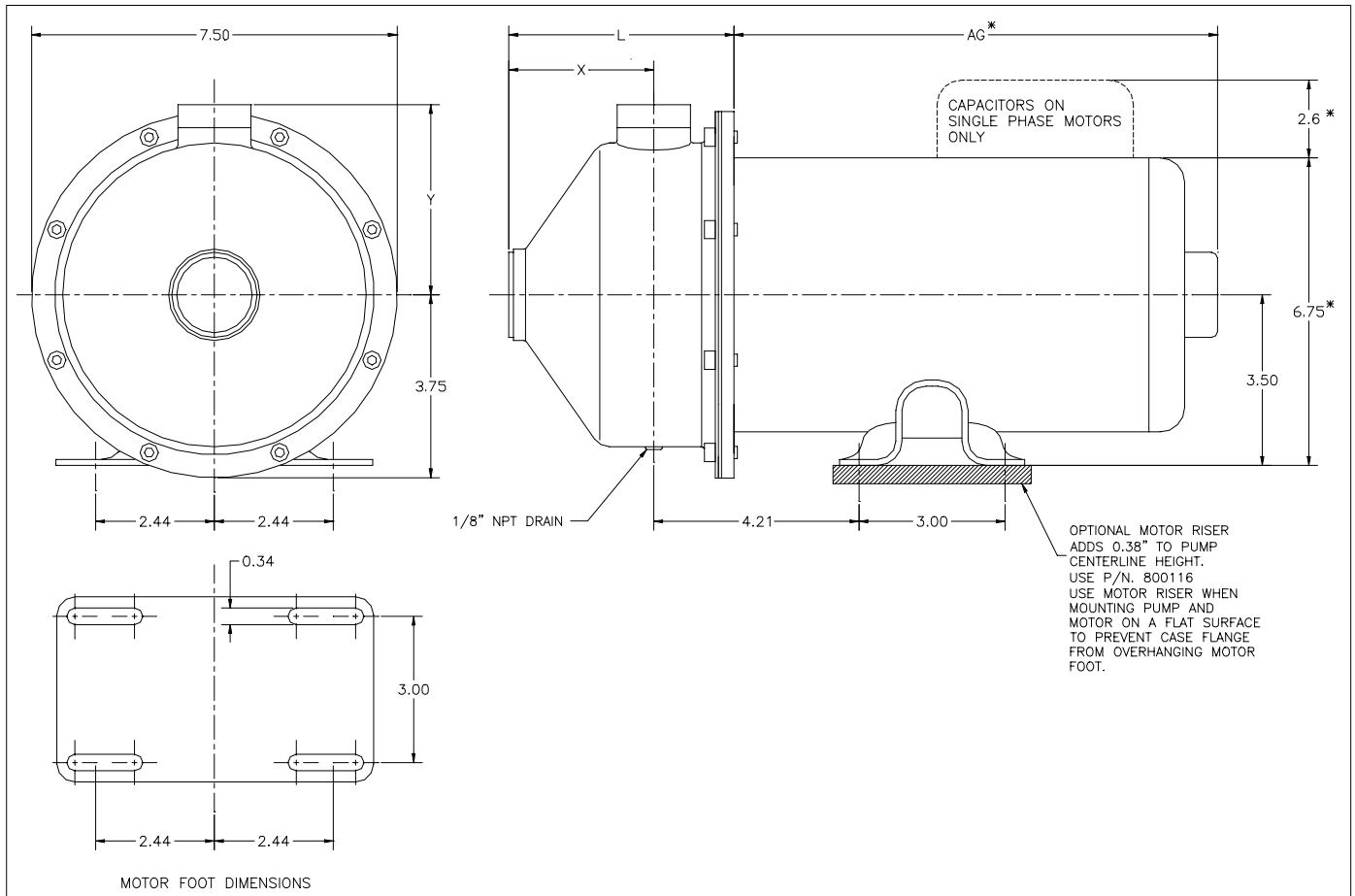

SSP & SSPC Dimensions With Standard Footed Motor



* Dimensions may vary by motor manufacturer and motor enclosure. Weights and dimensions listed are the largest for each motor horsepower size likely to be encountered. "Certified for Construction" drawings are available upon request.

Size	Suction	Discharge	L	X	Y	Motor HP	AG	Ship Wgt.
1SSP/C	1.25 NPT	1.0 NPT	4.7	3.1	3.9	1/2	10.0	29
						3/4	10.3	31
						1.0	11.3	33
						1.5	11.5	37
						2.0	12.1	42
2SSP/C	2.0 NPT	1.5 NPT	4.3	2.7	4.5	3.0	12.5	51
						1.0	11.3	33
						1.5	11.5	37
						2.0	12.1	42
						3.0	12.5	51
						5.0	13.5	55

All dimensions in inches. Shipment weight includes packaging.